



## Modular Cooking Range Line thermaline 90 - 2-Burner Gas Top with Ecoflam, 1 Side

ITEM # \_\_\_\_\_

MODEL # \_\_\_\_\_

NAME # \_\_\_\_\_

SIS # \_\_\_\_\_

AIA # \_\_\_\_\_

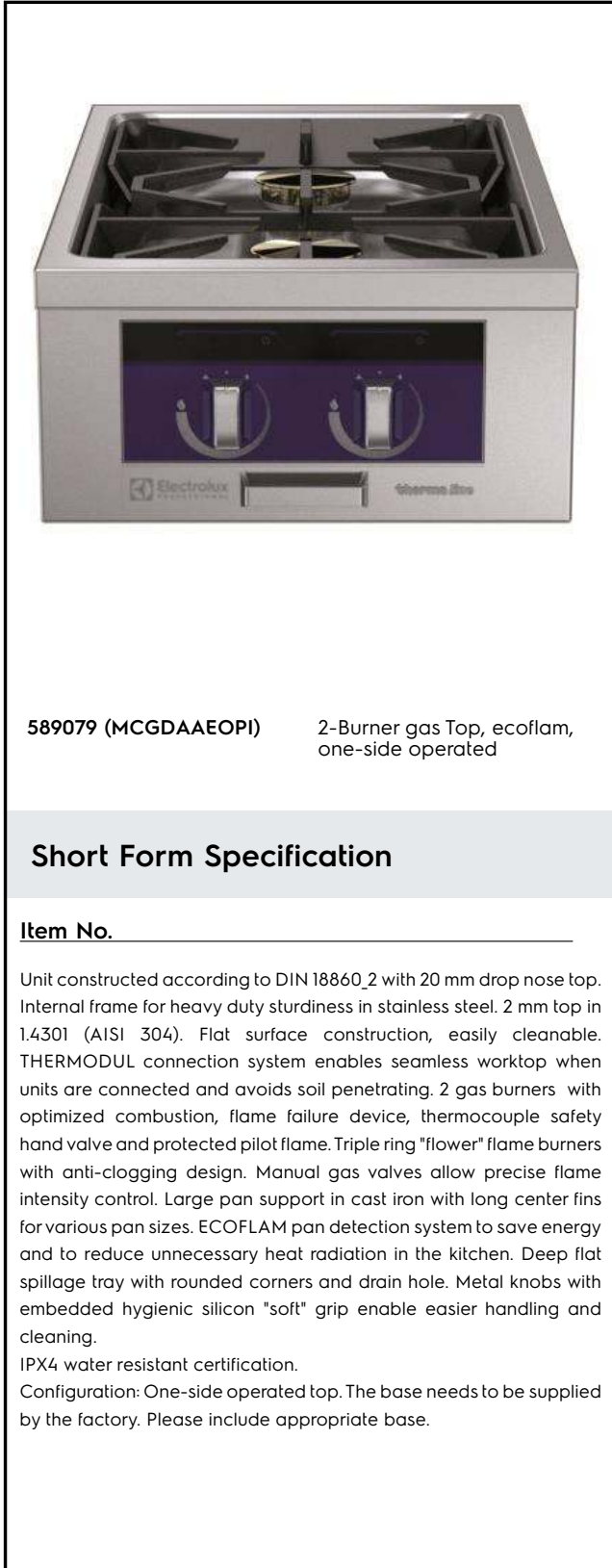

589079 (MCGDAAEOP1) 2-Burner gas Top, ecoflam, one-side operated

### Short Form Specification

**Item No.** \_\_\_\_\_

Unit constructed according to DIN 18860\_2 with 20 mm drop nose top. Internal frame for heavy duty sturdiness in stainless steel. 2 mm top in 1.4301 (AISI 304). Flat surface construction, easily cleanable. THERMODUL connection system enables seamless worktop when units are connected and avoids soil penetrating. 2 gas burners with optimized combustion, flame failure device, thermocouple safety hand valve and protected pilot flame. Triple ring "flower" flame burners with anti-clogging design. Manual gas valves allow precise flame intensity control. Large pan support in cast iron with long center fins for various pan sizes. ECOFLAM pan detection system to save energy and to reduce unnecessary heat radiation in the kitchen. Deep flat spillage tray with rounded corners and drain hole. Metal knobs with embedded hygienic silicon "soft" grip enable easier handling and cleaning.

IPX4 water resistant certification.

Configuration: One-side operated top. The base needs to be supplied by the factory. Please include appropriate base.

### Main Features

- Flame failure device on each burner protects against gas leakage when accidental extinguishing of the flame occurs.
- Large sized pan support in cast iron with long center fins to allow the use of the largest down to the smallest pans.
- Manual gas valves allow precise control of the flame intensity between high and low positions.
- Pans can easily be moved from one area to another without lifting.
- All major components may be easily accessed from the front.
- THERMODUL connection system creates a seamless work top when units are connected to each other thus avoiding soil penetrating vital components and facilitating the removal of units in case of replacement or service.
- Metal-covered knobs with embedded hygienic "soft-touch" grip for easier handling and cleaning. The special design of the controls prevents infiltration of liquids or soil into vital components.
- Burners with optimized combustion. Triple ring flower flame burners with anti-clogging design.
- Deep flat spillage tray with rounded corners and drain hole to facilitate cleaning.
- Patented Flower Flame burners that adjust to the size and form of the cookware (Patent EP2708813B1 and related family).

### Construction

- Each burner equipped with thermocouple safety hand valve and protected pilot flame.
- 2 mm top in 1.4301 (AISI 304).
- Flat surface construction with minimal hidden areas to easily clean all surfaces
- Internal frame for heavy duty sturdiness in 1.4301 (AISI 304).
- IPx4 water protection.
- Unit constructed according to DIN 18860\_2 with 20 mm drop nose top.
- Unit constructed according to DIN 18860\_2 with 20 mm drop nose top and 70 mm recessed plinth.

### Sustainability

- Model is supplied with Ecoflam pan detection system, which reduces energy consumption and unnecessary heat dispersion in the kitchen.



APPROVAL: \_\_\_\_\_



Front

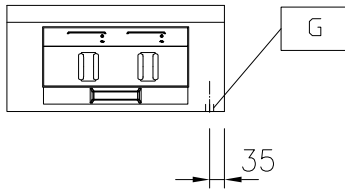

Side

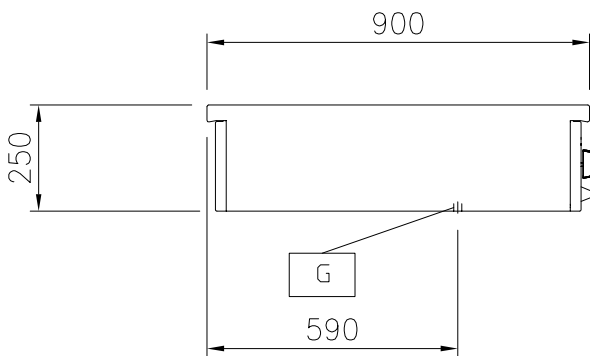

EQ = Equipotential screw  
 G = Gas connection

Top

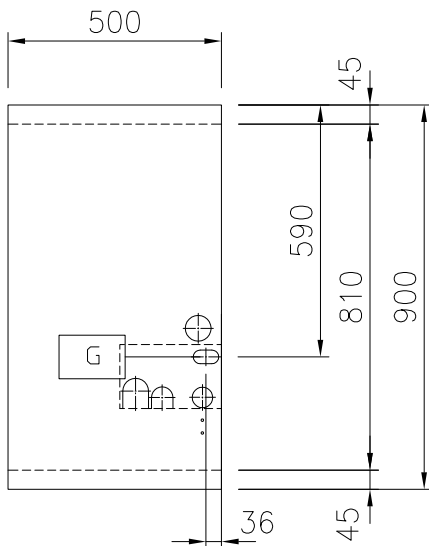

### Gas

Gas Power:	20 kW
Gas Type Option:	
Gas Inlet:	1/2"

### Key Information:

External dimensions, Width:	500 mm
External dimensions, Depth:	900 mm
External dimensions, Height:	250 mm
Net weight:	41 kg
Configuration:	One-Side Operated;Top
Front Burners Power:	ISO 9001; ISO 14001 - kW
Back Burners Power:	10 - 0 kW
Back Burners Dimension - mm	Ø 70
Front Burners Dimension - mm	Ø 70

### Optional Accessories

- Connecting rail kit, 900mm PNC 912502
- Portioning shelf, 500mm width PNC 912523
- Portioning shelf, 500mm width PNC 912553
- Folding shelf, 300x900mm PNC 912581
- Folding shelf, 400x900mm PNC 912582
- Fixed side shelf, 200x900mm PNC 912589
- Fixed side shelf, 300x900mm PNC 912590
- Fixed side shelf, 400x900mm PNC 912591
- Connecting rail kit: modular 90 (on the left) to ProThermetic tilting (on the right), ProThermetic stationary (on the left) to ProThermetic tilting (on the right) PNC 912975
- Connecting rail kit: modular 80 (on the right) to ProThermetic tilting (on the left), ProThermetic stationary (on the right) to ProThermetic tilting (on the left) PNC 912976
- Endrail kit, flush-fitting, left PNC 913111
- Endrail kit, flush-fitting, right PNC 913112
- Endrail kit (12.5mm) for thermaline 90 units, left PNC 913202
- Endrail kit (12.5mm) for thermaline 90 units, right PNC 913203
- T-connection rail for back-to-back installations without backsplash (to be ordered as S-code) PNC 913227
- Insert profile d=900 PNC 913232
- Endrail kit, (12.5mm), for back-to-back installation, left PNC 913251
- Endrail kit, (12.5mm), for back-to-back installation, right PNC 913252
- Endrail kit, flush-fitting, for back-to-back installation, left PNC 913255
- Endrail kit, flush-fitting, for back-to-back installation, right PNC 913256
- Kit LPG nozzles for 2 burner (10 kW) gas 30/31 PNC 913288
- Gas mainswitch for modular H800 gas units (factory fitted) PNC 913698